

## Principe schema ACV boiler met Dubbele Scheiding

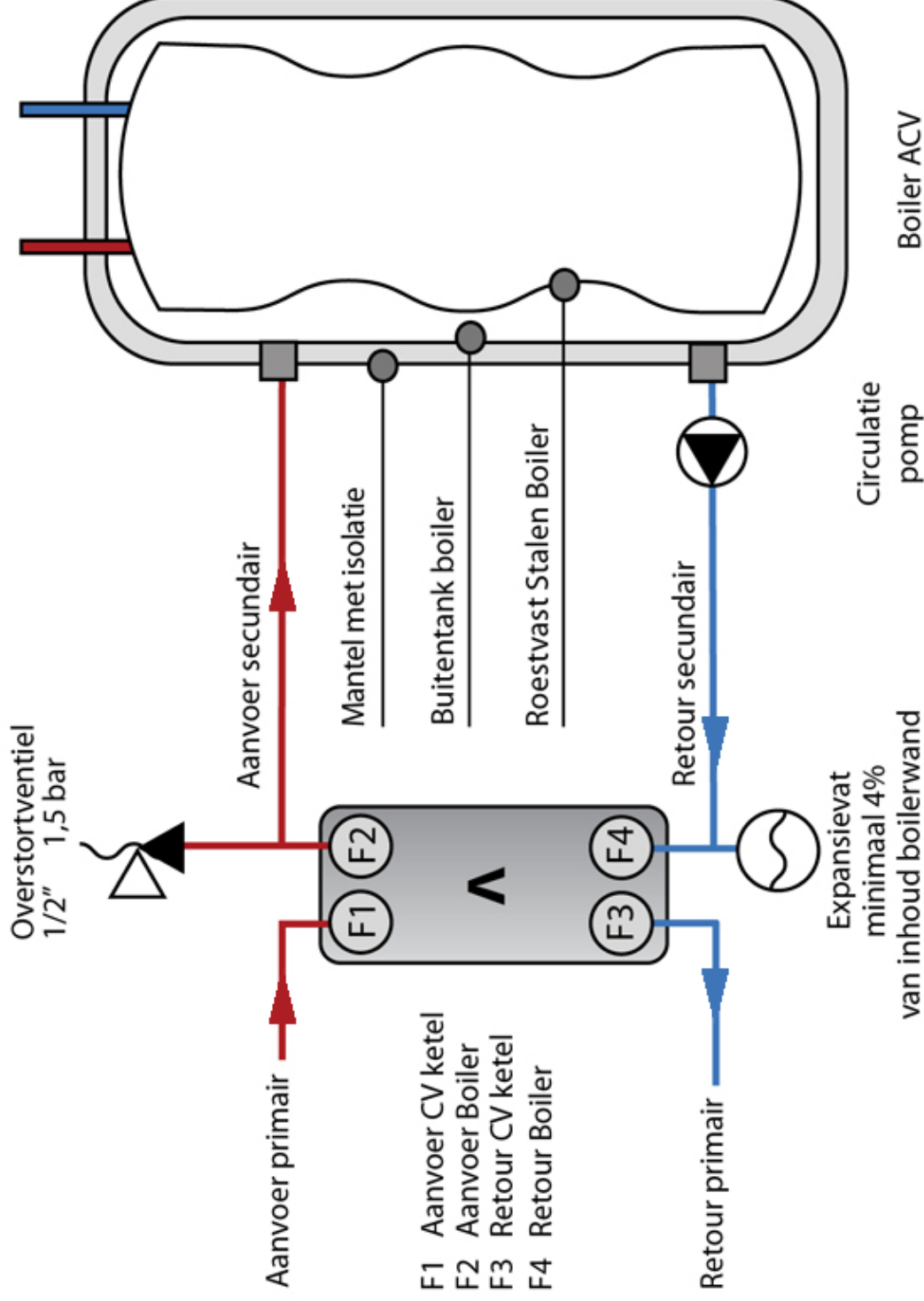
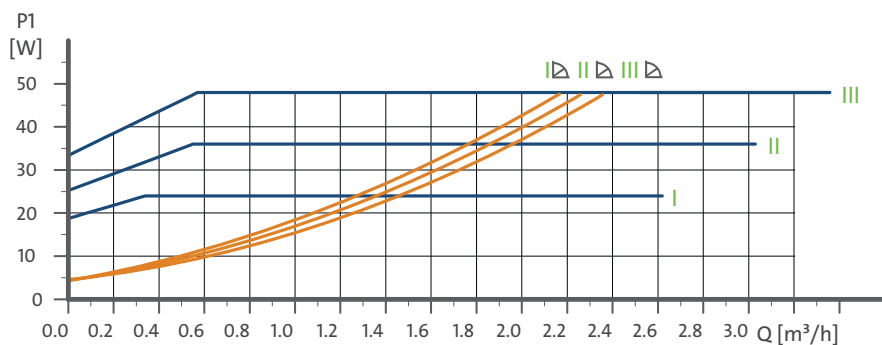
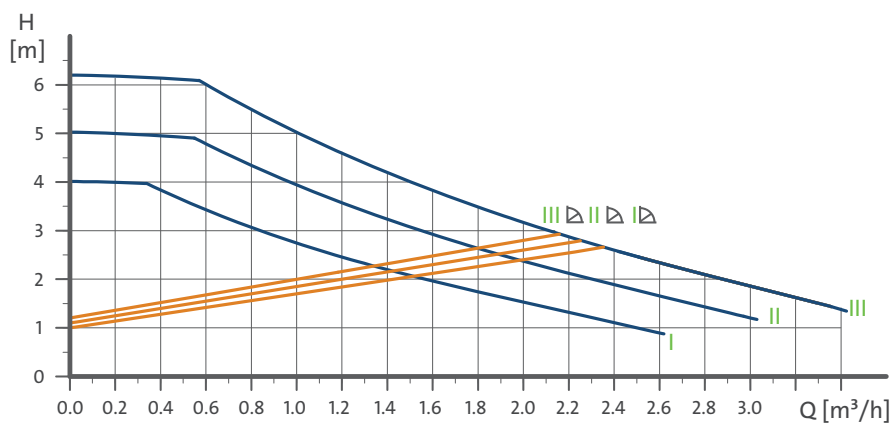

**UPS2 15-40/60 130, UPS2 25-40/60 130, UPS2 25-40/60 180, UPS2 PH-40/60**
**1 x 230 V, 50/60 Hz**

Speed	P1 [W]	I <sub>1/1</sub> [A]
Min.	7	0.06
Max.	48	0.42

System pressure: Maximum 10 bar.

Liquid temperature: 2-95 °C (TF 95).

The pump incorporates overload protection.

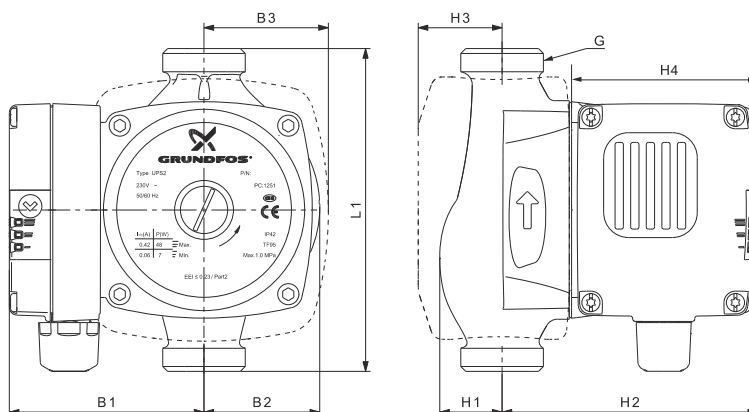

Pump type	Dimensions [mm]										Weights [kg]		Ship. vol. [m³]
	EEI ≤	L1	B1	B2	B3	H1	H2	H3	H4	G	Net	Gross	
UPS2 15-40/60	0.23	130	79	47	75	28	102	60	76	1	2.5	2.7	0.004
UPS2 25-40/60	0.23	130	79	47	75	29	102	60	76	1 1/2	2.7	2.9	0.004
	0.23	180	79	47	75	29	102	60	76	1 1/2	2.7	2.9	0.004
UPS2 PH-40/60	0.23	-	-	-	-	-	-	-	76	-	1.7	1.9	0.004



A DOVER COMPANY

## Specificatie van SWEP

Position: 1

Klant: **Inoxcon**  
SWEP CBE: **B16Hx30/1P-SC-S 4x1 1/4"**  
Artikelnummer: **12442- 30**

**Kant 1**

**Kant 2**

### Ontwerp gegevens

Medium	:	Water	Water
Intrede temperatuur	:	90 °C	60 °C
Uitrede temperatuur	:	70 °C	80 °C
	:		
Massastroom	:	2,205 m³/h	2,196 m³/h

### Platenwarmtewisselaar

Capaciteit	:	50,00 kW	
Totaal warmtewisselend opp.	:	1,12 m²	
Gem. temp. verschil	:	10 K	
Berekende drukval	:	7,69 kPa	6,83 kPa
Kanalen	:	14	15
Aantal platen	:	30	
Warmteoverdrachtscoëff.	:	5440/4460 W/m²,°C	
Overdimensionering	:	21,8 %	

### Aansluiting

Standaard aansluiting	F1	45696	ISO-G 1 1/4" A	P1
	F2	45696	ISO-G 1 1/4" A	P2
	F3	45696	ISO-G 1 1/4" A	P3
	F4	45696	ISO-G 1 1/4" A	P4
	F5			P5
	F6			P6

Plaats aansluiting in/uit	:	F3 / F1	F2 / F4
---------------------------	---	---------	---------

### Technische omschrijving

Plaatmateriaal	:	AISI 316	
Hardsoldeermateriaal	:	Koper	
Testdruk	:	50 bar	
Maximum werkdruk	:	31/27 / 31/27 bar	
Maximum werktemperatuur	:	155 / 225 °C	
Volume inwending	:	1,15 dm³	1,23 dm³
Dikte platenpakket	:	77,2 mm	
Breedte	:	119 mm	
Hoogte	:	376 mm	
Gewicht - leeg	:	4,92 kg	
Gewicht - in bedrijf	:	7,24 kg	

Comment:



A DOVER COMPANY

## Specificatie van SWEP

Position: 2

Klant: **Inoxcon**  
SWEP CBE: **B16Hx30/1P-SC-S 4x1 1/4"**  
Artikelnummer: **12442- 30**

### Kant 1

### Kant 2

#### Ontwerp gegevens

Medium	:	Water	Water
Intrede temperatuur	:	90 °C	60 °C
Uitrede temperatuur	:	70 °C	80 °C
Massastroom	:	2,646 m³/h	2,635 m³/h

#### Platenwarmtewisselaar

Capaciteit	:	60,00 kW	
Totaal warmtewisselend opp.	:	1,12 m²	
Gem. temp. verschil	:	10 K	
Berekende drukval	:	11,1 kPa	9,64 kPa
Kanalen	:	14	15
Aantal platen	:	30	
Warmteoverdrachtscoëff.	:	6090/5360 W/m²,°C	
Overdimensionering	:	13,6 %	

#### Aansluiting

Standaard aansluiting	F1	45696	ISO-G 1 1/4" A	P1
	F2	45696	ISO-G 1 1/4" A	P2
	F3	45696	ISO-G 1 1/4" A	P3
	F4	45696	ISO-G 1 1/4" A	P4
	F5			P5
	F6			P6
Plaats aansluiting in/uit	:	F3 / F1		F2 / F4

#### Technische omschrijving

Plaatmateriaal	:	AISI 316	
Hardsoldeermateriaal	:	Koper	
Testdruk	:	50 bar	
Maximum werkdruk	:	31/27 / 31/27 bar	
Maximum werkteemperatuur	:	155 / 225 °C	
Volume inwending	:	1,15 dm³	1,23 dm³
Dikte platenpakket	:	77,2 mm	
Breedte	:	119 mm	
Hoogte	:	376 mm	
Gewicht - leeg	:	4,92 kg	
Gewicht - in bedrijf	:	7,24 kg	

Comment:

**EPP** | Insulation



This insulation for heating applications consists of 2 half-shells and is made of expanded polypropylene. Due to the half-shell system, the assembly on the already installed heat exchanger is possible.

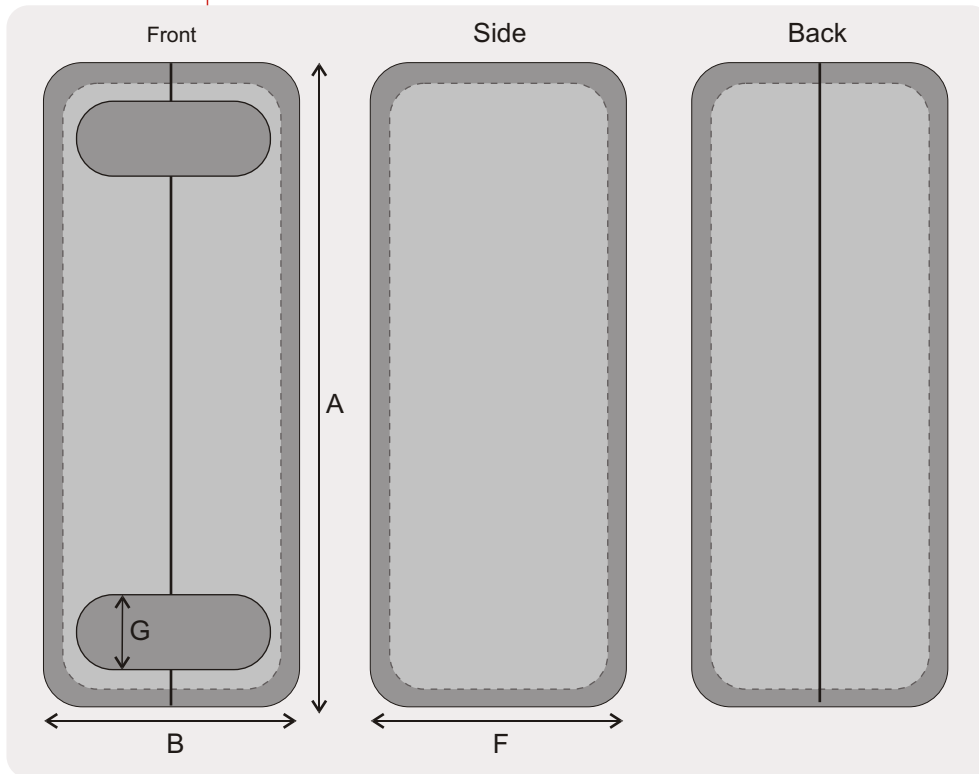

Only available for units with all connections on one side.

SWEP accessories meet the same high standards as the company's BPHEs. They are produced according to SWEP's specification by rigorously selected suppliers. The high quality materials are carefully chosen for compatibility, while the accurate dimensions save you time and money on installation.

With SWEP accessories you have the assurance that everything will fit and perform the way the design engineers intended.

### Technical data

Max operating temperature	+110°C
Thermal conductivity	0.035 W/mK
Fire properties	B2 in accordance with DIN4102
Material	Expanded Polypropylene
Specific gravity	40 kg/m <sup>3</sup>

### Dimensions

Size NoP	5T 20/40	8T 20/30/40	15 20/40	10T/12 20/40/60/80	16/26 40/60/80/100	25T/28/80 20/30/40/60/80/100
A mm	252	376	524	350	437	587
B mm	136	136	132	179	179	179
F mm	117/163	117/140/163	118/163	121/168/215/263	160/206/250/296	118/137/165/212/260/306
G mm	40	40	40	50	50	50
Thickness mm	29	29	29	29	29	29